



Features:

- Compliant with SFP MSA standard
- Compliant with IEEE 802.3z
- 3.3V DC power supply
- 850nm, VCSEL, 1250Mbps, 550m
- Difference LVPECL inputs and outputs
- Duplex LC connector
- Compliant with SFF-8472
- Hot Pluggable
- ROHS compliant



Application:

- Gigabit Ethernet data link
- Data storage networks
- Other optical links
- Optical access network

Description

AOD 1250Mbps multi-mode SFP is a high performance and cost effective transceiver. It is designed to meet Gigabit Ethernet application. The transceiver consists two sections: the transmitter section consists of a high reliability 850nm VCSEL with monitor photo detector (MPD) in eye safety; the receiver section consists of a high-speed GaAs PIN photodiode (PD) and trans-impedance preamplifier. The output of the PD drives the post-amplification, quantizing, and optical signal detection circuits. The receiver is built in the LOS monitoring function. For further information, please see SFP MSA and SFF-8472 standard.

Block Diagram

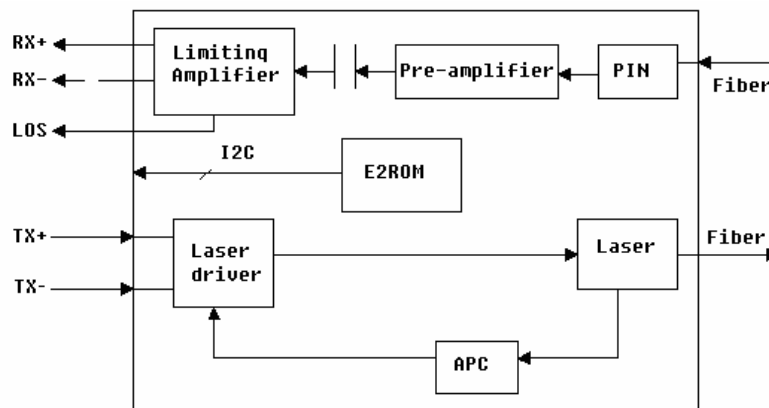



PECL Logic Level

Logic State	Unit	Min	Typ	Max
Low	V	VCC-1.84	-	VCC-1.60
High	V	VCC-1.10	-	VCC-0.90

TTL Logic Level

Logic State	Unit	Min	Typ	Max
Low	V	0	-	0.8
High	V	2.4	-	VCC

Transceiver Pin Locations

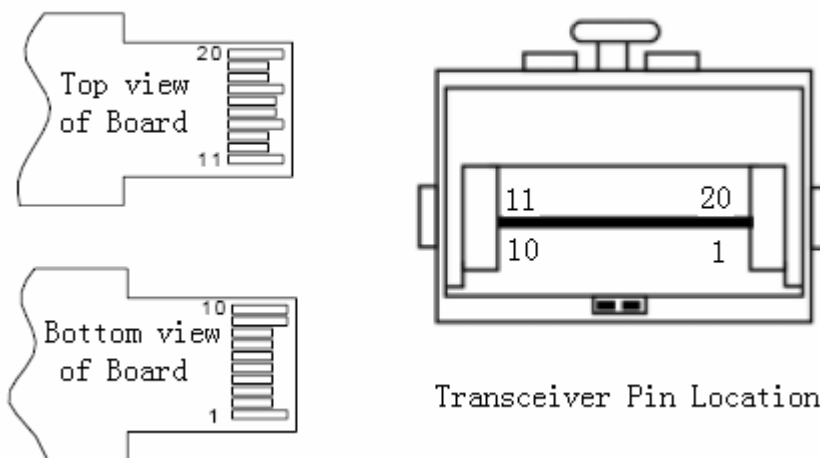

Pin Descriptions

Pin	Name	Description	Plug Sequence	Note
1	VEET	Transmitter Ground	1	
2	TX Fault	Transmitter Fault Indication	3	1



3	TX Disable	Transmitter Disable	3	2
4	MOD-DEF2	Module Definition 2	3	3
5	MOD-DEF1	Module Definition 1	3	3
6	MOD-DEF0	Module Definition 0	3	3
7	Rate Select	Not Connected	3	
8	LOS	Loss of Signal	3	4
9	VeeR	Receiver Ground	1	
10	VeeR	Receiver Ground	1	
11	VeeR	Receiver Ground	1	
12	RD-	Inverse Received Data Out	3	5
13	RD+	Received Data Out	3	5
14	VeeR	Receiver Ground	1	
15	VccR	Receiver Power	2	
16	VccT	Transmitter Power	2	
17	VeeT	Transmitter Ground	1	
18	TD+	Transmit Data In	3	6
19	TD-	Inverse Transmit Data In	3	6
20	VeeT	Transmitter Ground	1	

Note:

- 1, TX Fault is an open collector output, which should be pulled up with a 4.7k~10kΩ resistor on the host board to a voltage between 2.0V and Vcc+0.3V. Logic 0 indicates normal operation; logic 1 indicates a laser fault of some kind. In the low state, the output will be pulled to less than 0.8V.
2. TX Disable is an input that is used to shut down the transmitter optical output. It is pulled up within the module with a 4.7k~10kΩ resistor. Its states are:
Low (0~0.8V): Transmitter on (>0.8V, <2.0V): Undefined
High (2.0~3.465V): Transmitter Disabled
Open: Transmitter Disable
3. MOD-DEF 0, 1, 2 are the module definition pins. They should be pulled up with a 4.7k~10kΩ resistor on the host board. The pull-up voltage shall be VccT or VccR.
MOD-DEF 0 is grounded by the module to indicate that the module is present
MOD-DEF 1 is the clock line of two wire serial interface for serial ID



- MOD-DEF 2 is the data line of two wire serial interface for serial ID
4. LOS is an open collector output, which should be pulled up with a 4.7k~10kΩ resistor on the host board to a voltage between 2.0V and Vcc+0.3V. Logic 0 indicates normal operation; logic 1 indicates loss of signal. In the low state, the output will be pulled to less than 0.8V.
 5. These are the differential receiver outputs. They are AC-coupled 100Ω differential lines which should be terminated with 100Ω (differential) at the user SERDES.
 6. These are the differential transmitter inputs. They are AC-coupled, differential lines with 100Ω differential termination inside the module.

Absolute Maximum Ratings

Parameter	Symbol	Min	Max	Unit
Storage Temperature	T _S	-40	85	°C
Operating Temperature	T _O	0	70	°C
Storage Relative Humidity	RH _S	-	95	%
Power Supply	VCC	-	5.5	V
Lead Solder Temperature	T _{SLD}	-	260	°C
Lead Solder Duration	t _{SLD}	-	10	s
Voltage on any input/output pin	V _{IO}	0	VCC	V

Performance Specification

Transmitter Characteristics						
Parameter	Symbol	min	Typ	Max	Unit	Note
Supply Voltage	VCC	3.15	3.3	3.45	V	-
Operation Current	I _{CC}	-	-	130	mA	-
Differential Input Voltage	V _{IN}	400	-	1600	mV	-
Data Rate	Rate	-	1250	-	Mbps	-
Optical Output Power	P _O	-9	-	-3	dBm	-
Extinction Ratio	ER	10	-	-	dB	-
Central Wavelength	λ	830	850	860	nm	-



Output Spectrum Width	$\Delta\lambda$	-	-	0.85	nm	nm
-----------------------	-----------------	---	---	------	----	----

Optical Rise Time	T_r	-	-	0.26	ns	20%~80%
Optical Fall Time	T_f	-	-	0.26	ns	20%~80%
Eye Diagram	Compliant IEEE 802.3z					-

Receiver Characteristics						
Parameter	Symbol	min	Typ	Max	Unit	Note
Supply Voltage	VCC	3.14	3.3	3.47	V	-
Operation Current	I_{OC}	-	-	120	mA	-
Differential Output Voltage	V_{OUT}	400	-	2000	mV	1
Data Rate	Rate	-	1250	-	Mbps	-
Sensitivity	S	-	-	-18	dBm	2
Optical Input Overload	P_{OL}	-3	-	-	dBm	-
Central Wavelength	λ	770	-	860	nm	-
SD (Signal Detected)	Optical Decreased	-35	-	-	dBm	-
	Optical Increased	-	-	-18	dBm	-
SD Hysteresis	P_H	0.5	-	5	dB	-

Note1: Internally AC coupled.

Note2: Average received power where the BER = 10^{-12} , measured with a 2^7-1 NRZ test pattern..

Power Supply

The Transceiver includes internal circuit components to filter power supply noise. Under some conditions of EMI and power supply noise, external power supply filtering may be necessary. If receiver sensitivity is found to be degraded by power supply noise, the filter network illustrated in the following figure may be used to improve performance. The values of the filter components are general recommendations and may be changed to suit a particular system environment. Shielded inductors are recommended.

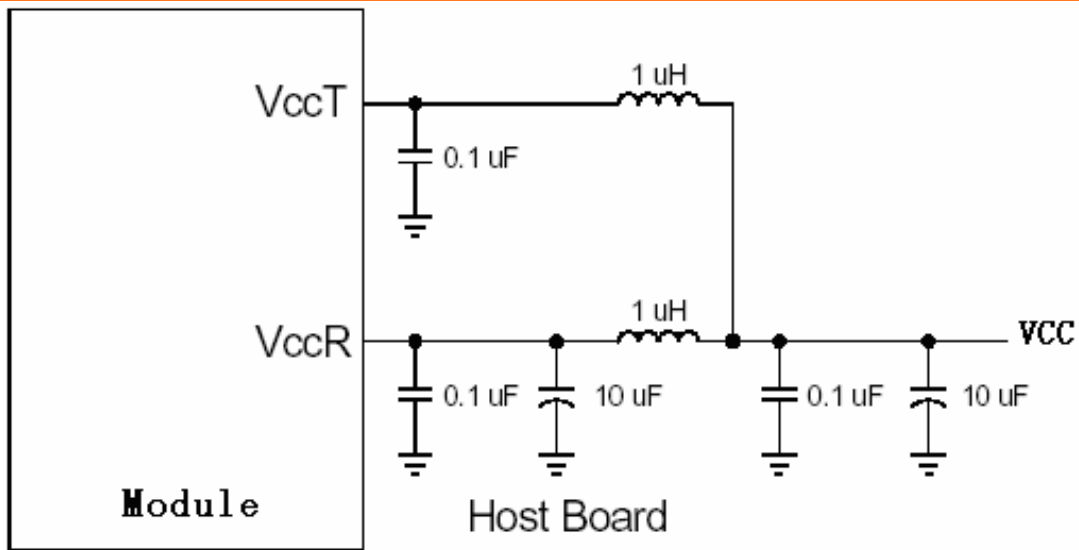

Recommended Application Circuits

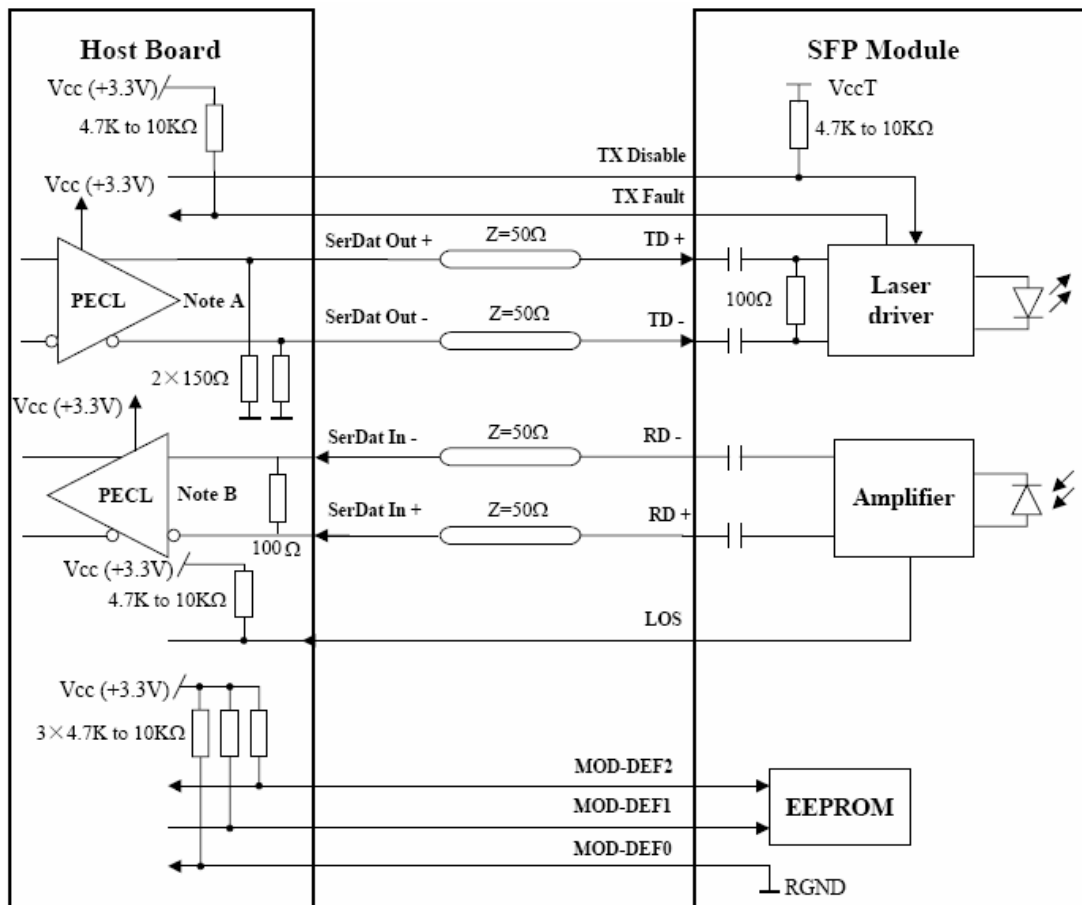



Recommended Front Panel Layout Opening for LC

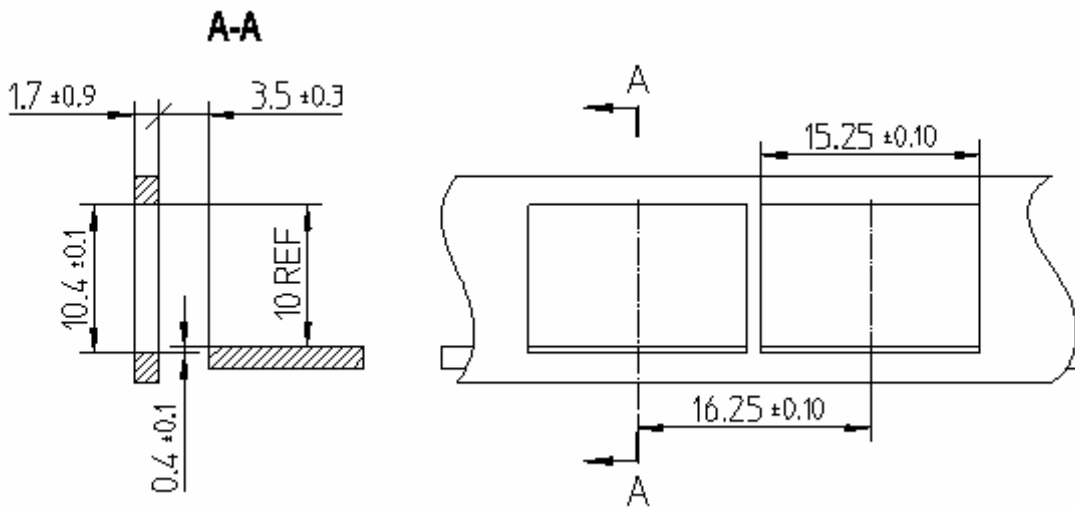

Outline Specification

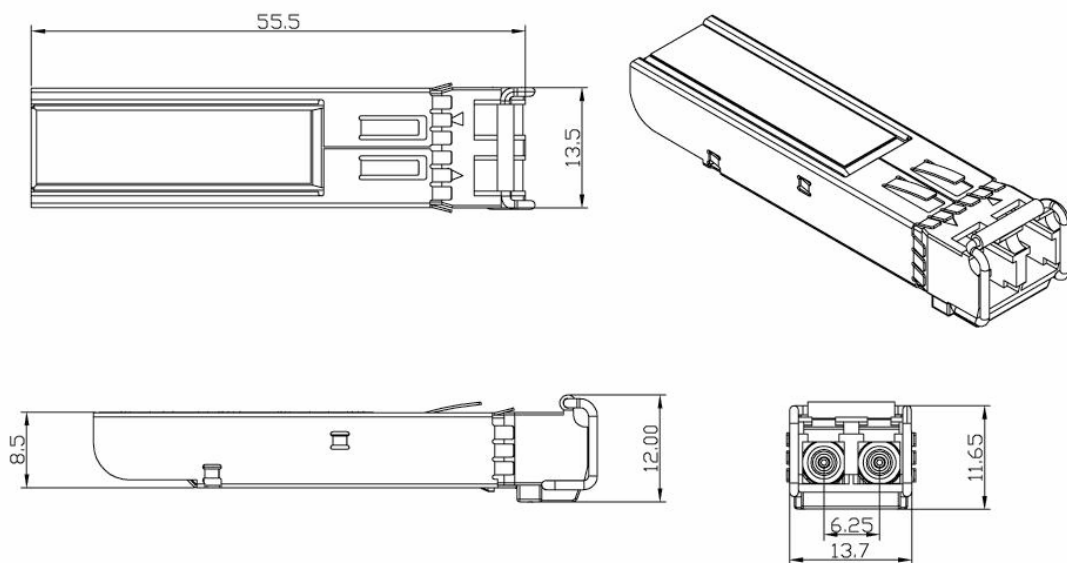

Ordering Information

Part Number	Wavelength	Monitor	LD Type	Temperature
AODM-PG85Z-LN-CV-PN	850nm	No DDM	VCSEL	-0°C ~70°C
AODM-PG85Z-LD-CV-PN	850nm	DDM	VCSEL	-0°C ~70°C